



CE MARK

- 20 WATTS MAXIMUM OUTPUT POWER
- 2:1 WIDE INPUT VOLTAGE RANGE
- INTERNATIONAL SAFETY STANDARD APPROVAL
- SIX-SIDED CONTINUOUS SHIELD
- HIGH EFFICIENCY UP TO 88%
- SMD TYPE 1.95" X 1.19" X 0.38" PACKAGE
- FIXED SWITCHING FREQUENCY
- PATENT

The SDC20 series offer 20 watts of output power from a 1.95 x 1.19 x 0.38 inch SMD type package. The SDC20 series with 2:1 wide input voltage of 36-75VDC and features 1600VDC of isolation, short-circuit and over-voltage protection, as well as six sided shielding. All models are particularly suited to telecommunications, industrial, mobile telecom and test equipment applications.

TECHNICAL SPECIFICATION All specifications are typical at nominal input, full load and 25°C otherwise noted

OUTPUT SPECIFICATIONS		
Output power		20 Watts max.
Voltage accuracy	Full load and nominal Vin	± 1%
Voltage adjustability		± 10%
Minimum load		0%
Line regulation	LL to HL at Full Load	± 0.2%
Load regulation	10% to 100% FL	± 0.5%
Ripple and noise	20MHz bandwidth (Measured with 0.1uF/50V MLCC)	See table
Temperature coefficient		±0.02% / °C, max.
Transient response recovery time	25% load step change	300uS
Over voltage Zener diode clamp	2.0V output	3.9V
	3.3V output	3.9V
	5V output	6.2V
	12V output	15V
	15V output	18V
Over load protection	% of FL at nominal input	150% max.
Short circuit protection		Hiccup, automatics recovery
INPUT SPECIFICATIONS		
Input voltage range	48V nominal input	36 – 75VDC
Input voltage lockout	DC-DC ON	36VDC
	DC-DC OFF	33VDC
Input filter		L-C type
Input surge voltage 100mS max	48V input	100VDC
Input reflected ripple	Nominal Vin and full load	25mA _{p-p}
Start up time (Note 1)	Nominal Vin and constant resistive load	Power up Remote ON/OFF
Remote ON/OFF (Note 2)	DC-DC ON	Open or 3.5V < Vr < 12V
	DC-DC OFF	Short or 0V < Vr < 1.2V
Remote off input current	Nominal Vin	2.5mA

GENERAL SPECIFICATIONS	
Efficiency	See table
Isolation voltage	1600VDC, min.
Isolation resistance	10 ⁹ ohms, min.
Isolation capacitance	500pF, max.
Switching frequency	300KHz, typ.
Design meet standard	IEC60950, UL1950, EN60950
Potting material	Epoxy (UL94-V0)
Dimensions	1.95 X 1.19 X 0.38 Inch (49.5 X 30.2 X 9.7 mm)
Weight	32.5g (1.15oz)
MTBF (Note 3)	1.632 x 10 ⁶ hrs
ENVIRONMENTAL SPECIFICATIONS	
Operating ambient temperature	-40°C ~ +85°C (with derating)
Maximum case temperature	+100°C
Storage temperature range	-55°C ~ +105°C
Thermal impedance	Nature convection
Thermal shock	14°C/Watt
Thermal shock	MIL-STD-810F
Vibration	MIL-STD-810F
Relative humidity	5% to 95% RH
EMC CHARACTERISTICS (Note 4)	
Conducted emissions	EN55022
	Class A
Radiated emissions	EN55022
	Class A
ESD	EN61000-4-2
	Perf. Criteria B
Radiated immunity	EN61000-4-3
	Perf. Criteria A
Fast transient	EN61000-4-4
	Perf. Criteria B
Surge	EN61000-4-5
	Perf. Criteria B
Conducted immunity	EN61000-4-6
	Perf. Criteria A

Model Number	Input Range	Output Voltage	Output Current	RIPPLE & NOISE ⁽⁵⁾	Input Current ⁽⁶⁾	Eff ⁽⁷⁾ (%)	Capacitor ⁽⁸⁾ Load max.
SDC20-48S2P0	36 – 75 VDC	2.0 VDC	4000mA	50mV	214mA	82	17000uF
SDC20-48S3P3	36 – 75 VDC	3.3 VDC	4000mA	50mV	344mA	84	10300uF
SDC20-48S05	36 – 75 VDC	5.0 VDC	4000mA	75mV	490mA	89	6800uF
SDC20-48S12	36 – 75 VDC	12.0 VDC	1670mA	75mV	497mA	88	1200uF
SDC20-48S15	36 – 75 VDC	15.0 VDC	1330mA	75mV	495mA	88	750uF

Note

- Please add an external filter at converter input terminals when measuring input reflected ripple, as figure 1.
L: Simulated source impedance of 12 μ H C: Nippon chemi-con KMF series, 220 μ F/100V.
- The ON/OFF control pin voltage is referenced to -Vin.
- BELLCORE TR-NWT-000332. Case I: 50% Stress, Temperature at 40°C. (Ground fixed and controlled environment)
- An external filter capacitor is required for EMC testing. The capacitor should be capable of handling 1A ripple current for 48V models. Power mate suggest: Nippon chemi-con KMF series, 220 μ F/100V, ESR 90m Ω .
- Test condition: nominal input and full load.
- Maximum value at nominal input voltage and full load.
- Typical value at nominal input voltage and full load.
- Test by minimum Vin and constant resistive load.

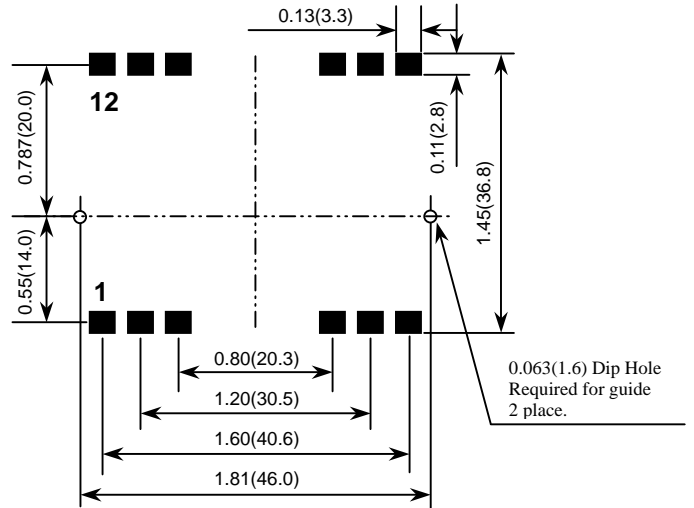
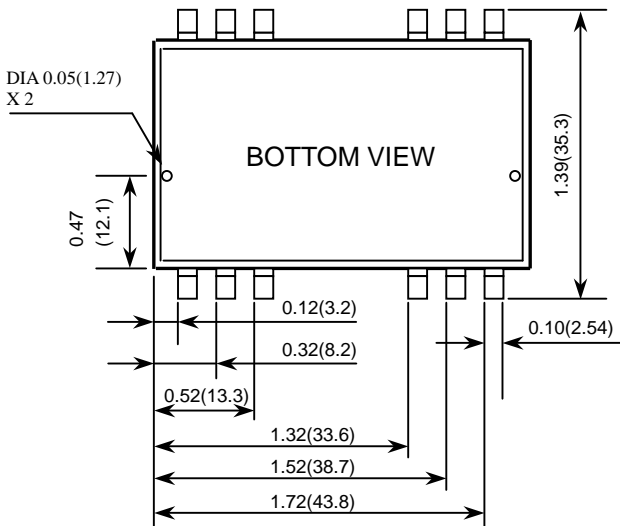
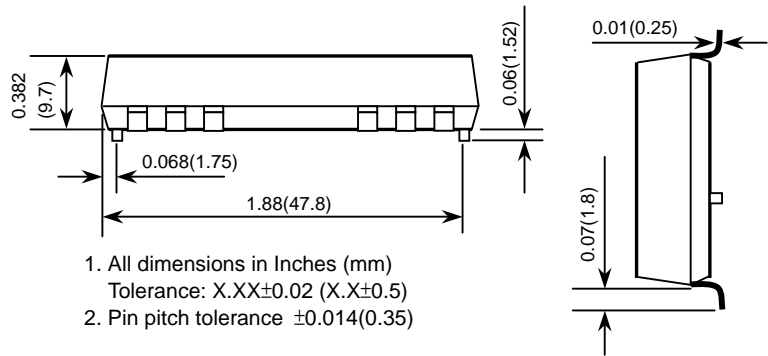
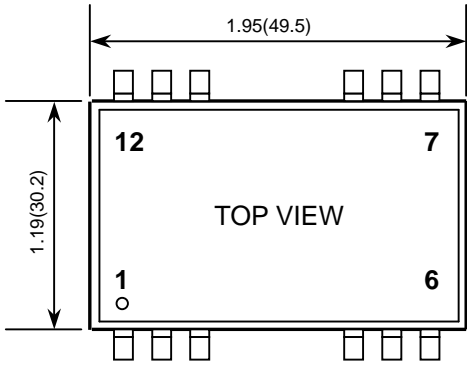
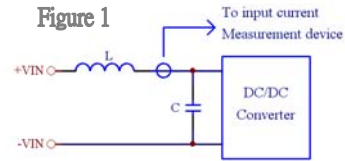

DIP PIN CONNECTION			
PIN	DEFINE	PIN	DEFINE
1	+ OUTPUT	12	+ INPUT
2	- OUTPUT	11	- INPUT
3	NC	10	NC
4	TRIM	9	SYNC
5	NC	8	ON-OFF CTRL
6	NC	7	NC

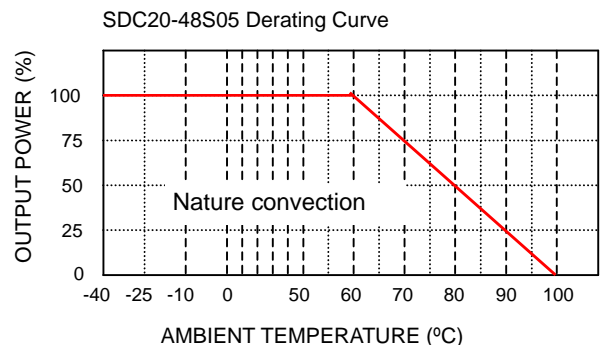

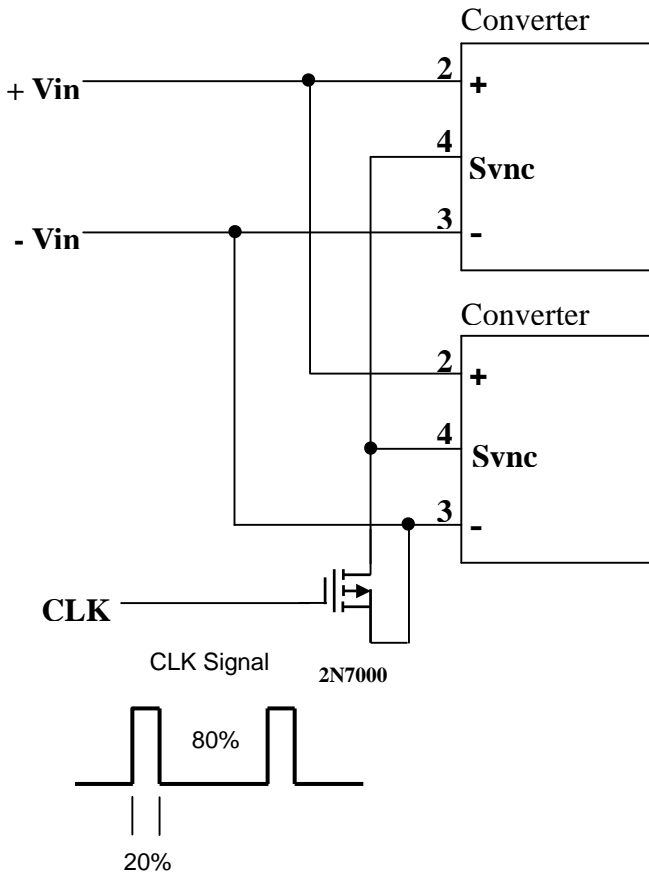

Application of synchronization

1. The unit is capable of external synchronization from an independent time base with a switching rate between 330KHz and 360KHz
2. The amplitude of the synchronizing pulse train is TTL compatible
3. The duty cycle of the CLK should be 20% high and 80% low
4. Synchronization is referenced to negative input (-Vin)

ON/OFF Control applicati

