

## LW030A Power Module: 36 Vdc to 75 Vdc Inputs; 30 W



The LW030A Power Module uses advanced, surface-mount technology and delivers high-quality, compact, dc-dc conversion at an economical price.

### Features

- Low profile: 9.5 mm (0.375 in.)
- Small size: 61 mm x 71 mm (2.40 in. x 2.80 in.)
- Wide input voltage range: 36 Vdc to 75 Vdc
- Output current limiting, unlimited duration
- Short circuit protection
- Output overvoltage clamp
- Input-to-output isolation
- Operating case temperature range: -40 °C to +100 °C
- Remote on/off
- Remote sense
- Output voltage adjust: 90% to 110% of  $V_{o, nom}$
- UL†60950 Recognized, CSA‡C22.2 No. 60950-00 Certified, and VDE§ 0805 Licensed
- CE mark meets 73/23/EEC and 93/68/EEC directives\*
- Within FCC and VDE Class A radiated limits

### Options

- Choice of on/off configuration
- Case ground pin
- Tight tolerance
- Synchronization

### Description

The LW030A Power Module is a low-profile dc-dc converter that operates over an input voltage range of 36 Vdc to 75 Vdc and provides precisely regulated 5 V output. The output is isolated from the input, allowing versatile polarity configurations and grounding connections. The module has a maximum power rating of 30 W at a typical full-load efficiency of 81%.

The power module features remote on/off, output sense (both negative and positive leads), and output voltage adjustment from 4.5 V to 5.5 V. Built-in filtering for both input and output minimizes the need for external filtering.

† UL is a registered trademark of Underwriters Laboratories, Inc.  
‡ CSA is a registered trademark of Canadian Standards Association.

§ VDE is a trademark of Verband Deutscher Elektrotechniker e.V.  
\* This product is intended for integration into end-use equipment. All the required procedures for CE marking of end-use equipment should be followed. (The CE mark is placed on selected products.)

## Absolute Maximum Ratings

Stresses in excess of the absolute maximum ratings can cause permanent damage to the device. These are absolute stress ratings only. Functional operation of the device is not implied at these or any other conditions in excess of those given in the operations sections of the data sheet. Exposure to absolute maximum ratings for extended periods can adversely affect device reliability.

Parameter	Symbol	Min	Max	Unit
Input Voltage Continuous	$V_I$	0	80	Vdc
Operating Case Temperature	$T_C$	-40	100	°C
Storage Temperature	$T_{stg}$	-40	120	°C
I/O Isolation Voltage	—	—	1050	Vdc

## Electrical Specifications

Unless otherwise indicated, specifications apply over all operating input voltage, resistive load, and temperature conditions.

**Table 1. Input Specifications**

Parameter	Symbol	Min	Typ	Max	Unit
Operating Input Voltage	$V_I$	36	48	75	Vdc
Maximum Input Current ( $V_I = 0\text{ V to }V_{I, \max}$ ; $I_O = I_{O, \max}$ )	$I_{I, \max}$	—	—	1.6	A
Inrush Transient	$i^2t$	—	—	1	A <sup>2</sup> s
Input Reflected-ripple Current	$I_r$	—	25	—	mAp-p
Input Ripple Rejection (100 Hz—120 Hz)	—	—	60	—	dB

## Fusing Considerations

**CAUTION: This power module is not internally fused. An input line fuse must always be used.**

This encapsulated power module can be used in a wide variety of applications, ranging from simple stand-alone operation to an integrated part of a sophisticated power architecture. To preserve maximum flexibility, internal fusing is not included; however, to achieve maximum safety and system protection, always use an input line fuse. The safety agencies require a normal-blow, dc fuse with a maximum rating of 5 A (see Safety Considerations section). Based on the information provided in this data sheet on inrush energy and maximum dc input current, the same type of fuse with a lower rating can be used. Refer to the fuse manufacturer's data for further information.

## Electrical Specifications (continued)

**Table 2. Output Specifications**

Parameter	Symbol	Min	Typ	Max	Unit
Output Voltage (Over all line, load, and temperature conditions until end of life.)	$V_o$	4.80	—	5.2	Vdc
Output Voltage Set Point ( $V_I = 48\text{ V}$ ; $I_o = I_{o, \text{max}}$ ; $T_C = 25\text{ }^\circ\text{C}$ )	$V_{o, \text{set}}$	4.92	—	5.08	Vdc
Output Regulation: Line ( $V_I = 36\text{ V to } 75\text{ V}$ ) Load ( $I_o = I_{o, \text{min}}$ to $I_{o, \text{max}}$ ) Temperature ( $T_C = -40\text{ }^\circ\text{C to } +100\text{ }^\circ\text{C}$ )	— — —	— — —	0.01 0.05 0.5	0.1 0.2 1.5	% $V_o$ % $V_o$ % $V_o$
Output Ripple and Noise RMS Peak-to-peak (5 Hz to 20 MHz)	— —	— —	— —	20 75	mVrms mVp-p
Output Current (At $I_o < I_{o, \text{min}}$ , the modules may exceed output ripple specifications.)	$I_o$	0.6	—	6.0	A
Output Current-limit Inception ( $V_o = 90\% \times V_{o, \text{set}}$ )	$I_o$	—	6.9	—	A
Output Short-circuit Current ( $V_o = 250\text{ mV}$ )	$I_o$	—	8.0	9.5	A
Efficiency ( $V_I, \text{nom}$ ; $I_o = I_{o, \text{max}}$ ; $T_C = 25\text{ }^\circ\text{C}$ )	$\eta$	79	81	—	%
Dynamic Response ( $\dot{I}_o/\dot{y}_t = 1\text{ A}/10\text{ }\mu\text{s}$ , $V_I = V_{I, \text{nom}}$ , $T_C = 25\text{ }^\circ\text{C}$ ): Load Change from $I_o = 50\%$ to $75\%$ of $I_{o, \text{max}}$ : Peak Deviation Settling Time ( $V_o < 10\%$ peak deviation) Load Change from $I_o = 50\%$ to $25\%$ of $I_{o, \text{max}}$ : Peak Deviation Settling Time ( $V_o < 10\%$ peak deviation)	— — — —	— — — —	2 5.0 2 5.0	— — — —	% $V_{o, \text{set}}$ ms % $V_{o, \text{set}}$ ms

**Table 3. Isolation Specifications**

Parameter	Min	Typ	Max	Unit
Isolation Capacitance	—	0.02	—	$\mu\text{F}$
Isolation Resistance	10	—	—	$M\Omega$



### Characteristic Curves

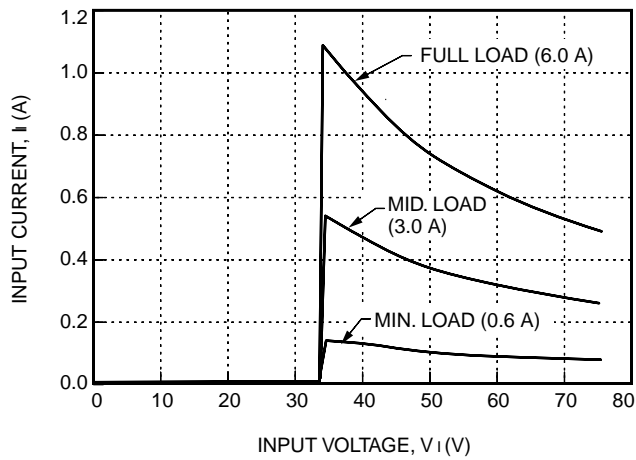

8-1268(C)

Figure 1. LW030A Typical Input Characteristics

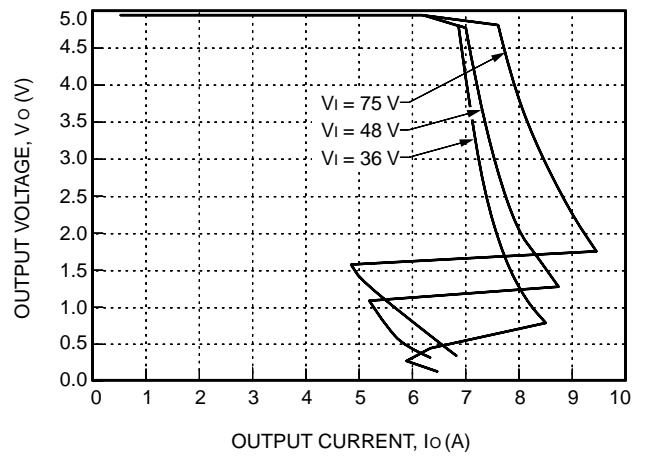

8-1269(C)

Figure 2. LW030A Typical Output Characteristics

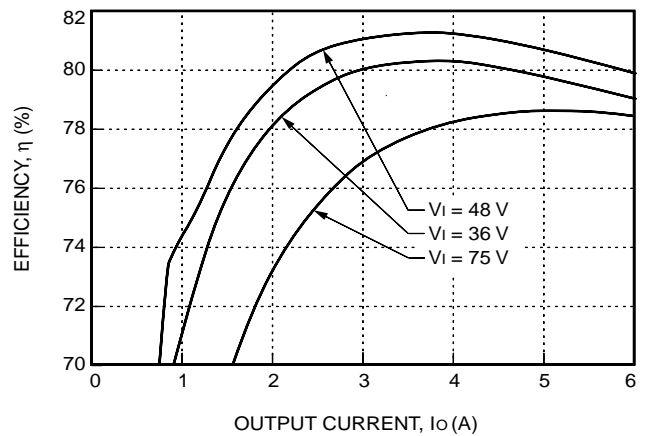

8-1270(C)

Figure 3. LW030A Typical Converter Efficiency vs. Output Current

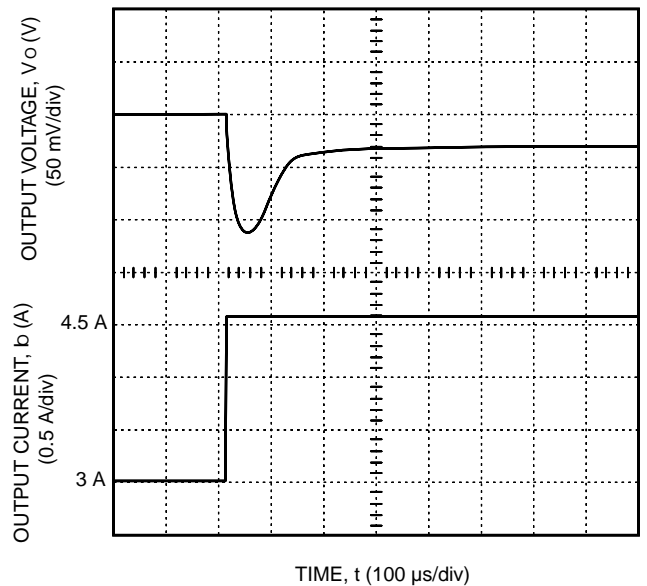

8-1271(C)

Figure 4. Typical Output Voltage for a Step Load Change from 50% to 75%

Characteristic Curves (continued)

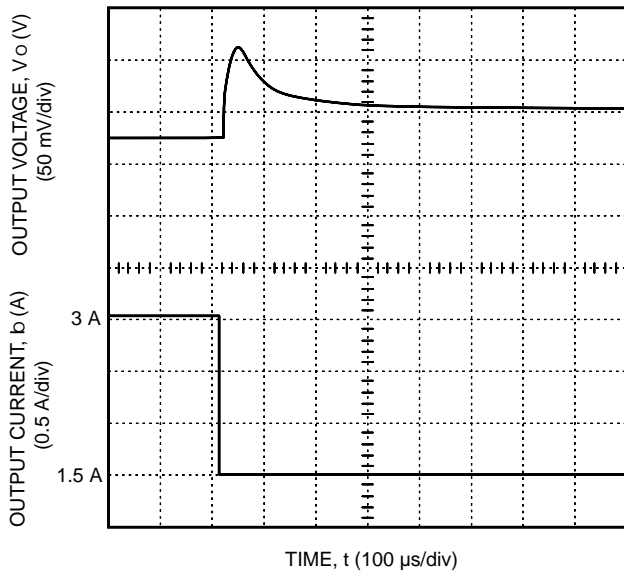

8-1272(C)

Figure 5. Typical Output Voltage for a Step Load Change from 50% to 25%

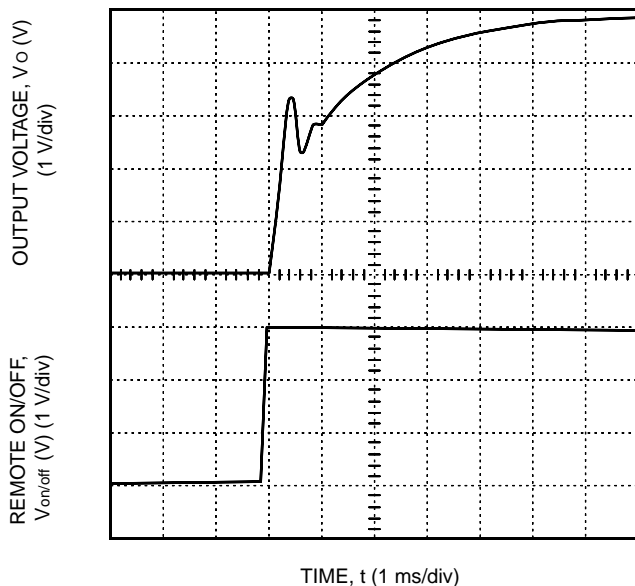

8-1273(C)

Figure 6. Typical Output Voltage Start-Up when Signal Applied to Remote On/Off

Test Configurations

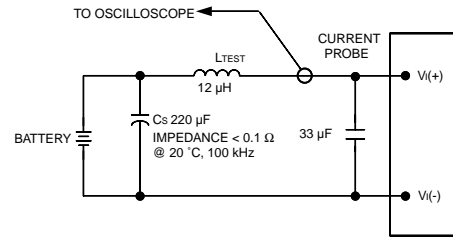

8-203(C)

Note: Input reflected-ripple current is measured with a simulated source impedance of 12  $\mu$ H. Capacitor  $C_s$  offsets possible battery impedance. Current is measured at the input of the module.

Figure 7. Input Reflected-Ripple Test Setup

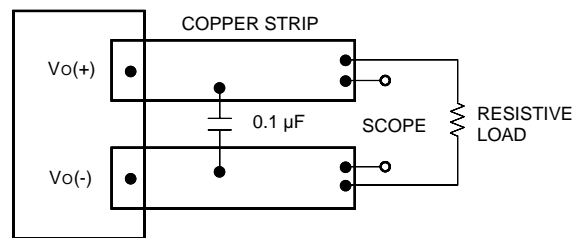

8-513(C)

Note: Use a 0.1  $\mu$ F ceramic capacitor. Scope measurement should be made using a BNC socket. Position the load between 50 mm (2 in.) and 75 mm (3 in.) from the module.

Figure 8. Peak-to-Peak Output Noise Measurement Test Setup

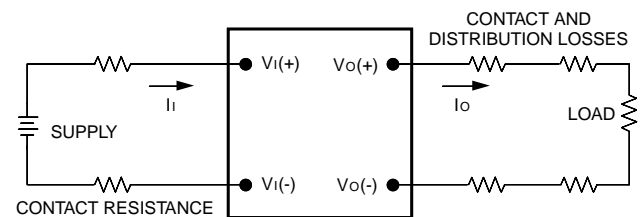

8-204(C)

Note: All measurements are taken at the module terminals. When socketing, place Kelvin connections at module terminals to avoid measurement errors due to socket contact resistance.

$$\eta = \left( \frac{[V_o(+)] - [V_o(-)] I_o}{[V_i(+)] - [V_i(-)] I_i} \right) \times 100$$

Figure 9. Output Voltage and Efficiency Measurement Test Setup

## Design Considerations

### Input Source Impedance

The power module should be connected to a low ac-impedance input source. Highly inductive source impedances can affect the stability of the power module. For the test configuration in Figure 1, a 33  $\mu$ F electrolytic capacitor (ESR < 0.7  $\frac{3}{4}$  at 100 kHz) mounted close to the power module helps ensure stability of the unit. For other highly inductive source impedances, consult the factory for further application guidelines.

### Safety Considerations

For safety-agency approval of the system in which the power module is used, the power module must be installed in compliance with the spacing and separation requirements of the end-use safety agency standard, i.e., UL-1950, CSA 22.2-950, EN60950.

For the converter output to be considered meeting the requirements of safety extra-low voltage (SELV), one of the following must be true:

- All inputs are SELV and floating, with the output also floating.
- All inputs are SELV and grounded, with the output also grounded.
- Any non-SELV input must be provided with reinforced insulation from any other hazardous voltages, including the ac mains, and must have a SELV reliability test performed on it in combination with the converters. Inputs must meet SELV requirement.

If the input meets extra-low voltage (ELV) requirements, then the converter's output is considered ELV.

The input to these units is to be provided with a maximum 5 A normal blow fuse in the ungrounded lead.

## Feature Descriptions

### Output Overvoltage Clamp

The output overvoltage clamp consists of control circuitry, independent of the primary regulation loop, that monitors the voltage on the output terminals. The control loop of the shutdown has a higher voltage set point than the primary loop (see Feature Specifications table). In a fault condition, the overvoltage clamp ensures that the output voltage does not exceed  $V_{O, \text{clamp, max}}$ . This provides a redundant voltage-control that reduces the risk of output overvoltage.

### Current Limit

To provide protection in a fault (output overload) condition, the unit is equipped with internal current-limiting circuitry and can endure current limiting for an unlimited duration. At the point of current-limit inception, the unit shifts from voltage control to current control. If the output voltage is pulled very low during a severe fault, the current-limit circuit can exhibit either foldback or tailout characteristics (output-current decrease or increase). The unit operates normally once the output current is brought back into its specified range.

### Remote On/Off

Two remote on/off options are available. Positive logic remote on/off turns the module on during a logic high voltage on the remote ON/OFF pin, and off during a logic low. Negative logic remote on/off, code suffix "1," turns the module off during a logic high and on during a logic low.

To turn the power module on and off, the user must supply a switch to control the voltage between the on/off terminal and the  $V_{I(-)}$  terminal ( $V_{\text{on/off}}$ ). The switch can be an open collector or equivalent (see Figure 10). A logic low is  $V_{\text{on/off}} = 0$  V to 1.2 V. The maximum  $I_{\text{on/off}}$  during a logic low is 1 mA. The switch should maintain a logic low voltage while sinking 1 mA.

During a logic high, the maximum  $V_{\text{on/off}}$  generated by the power module is 6 V. The maximum allowable leakage current of the switch at  $V_{\text{on/off}} = 6$  V is 50  $\mu$ A.

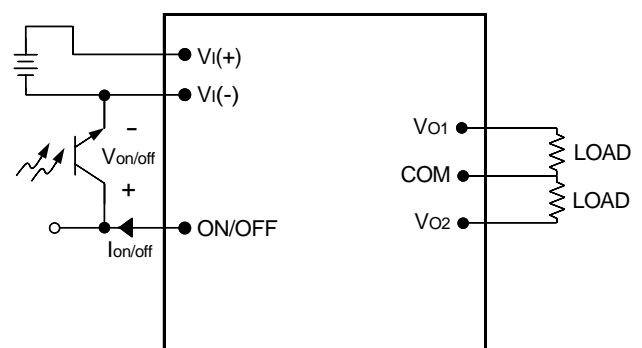

8-754 (C)

Figure 10. Remote On/Off Implementation

**Feature Descriptions** (continued)

**Output Voltage Adjustment**

Output voltage trim allows the user to increase or decrease the output voltage set point of a module. This is accomplished by connecting an external resistor between the TRIM pin and either the Vo(+) or Vo(-) pins. With an external resistor between the TRIM and Vo(+) pins (R<sub>adj-down</sub>), the output voltage set point (V<sub>O,adj</sub>) decreases. The following equation determines the required external resistor value to obtain an output voltage change of y%:

$$R_{\text{adj-down}} = \left[ \frac{8.47}{\Delta\%} - 16.94 \right] \text{k}\Omega$$

where R<sub>adj-down</sub> is the resistance value connected between TRIM and Vo (+).

For example, to lower the output voltage by 10%, the external resistor value must be:

$$R_{\text{adj-down}} = 67.8 \text{ k}\Omega$$

With an external resistor connected between the TRIM and Vo(-) pins (R<sub>adj-up</sub>), the output voltage set point (V<sub>O,adj</sub>) increases. The following equation determines the required external resistor value to obtain an output voltage change of y%:

$$R_{\text{adj-up}} = \left[ \frac{8.47}{\Delta\%} \right] \text{k}\Omega$$

where R<sub>adj-up</sub> is the resistance value connected between TRIM and Vo(-).

For example, to increase the output voltage of the LW030A by 10%, the external resistor value must be:

$$R_{\text{adj-up}} = 84.7 \text{ k}\Omega$$

The combination of the output voltage adjustment and sense range and the output voltage given in the Feature Specifications table cannot exceed 110% of the nominal output voltage between the Vo(+) and Vo(-) terminals.

The LW030A has a fixed current-limit set point. Therefore, as the output voltage is adjusted down, the available output power is reduced. In addition, the minimum output current is a function of the output voltage. As the output voltage is adjusted down, the minimum required output current can increase.

**Synchronization (Optional)**

The unit is capable of external synchronization from an independent time base with a switching rate between 290 kHz and 310 kHz. The amplitude of the synchronizing pulse train is TTL compatible, and the duty cycle ranges between 40% and 60%. Synchronization is referenced to the primary.

**Thermal Considerations**

**Introduction**

The LW030A power module operates in a variety of thermal environments; however, sufficient cooling should be provided to help ensure reliable operation of the unit. Heat-dissipating components inside the unit are thermally coupled to the case. Heat is removed by conduction, convection, and radiation to the surrounding environment. Proper cooling can be verified by measuring the case temperature. Peak temperature (T<sub>c</sub>) occurs at the position indicated in Figure 11.

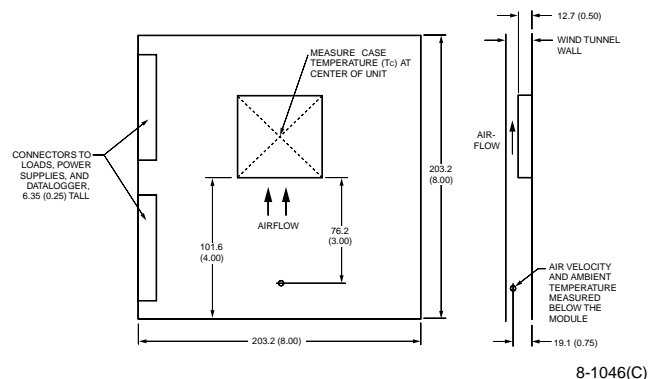

Note: Dimensions are in millimeters and (inches). Drawing is not to scale.

**Figure 11. Thermal Test Setup**

The temperature at this location should not exceed 100 °C. The output power of the module should not exceed the rated power for the module as listed in the Ordering Information table.

## Thermal Considerations (continued)

### Heat Transfer Without Heat Sinks

The thermal data presented in this section is based on measurements taken in a wind tunnel. The test setup shown in Figure 11 was used to collect data for Figures 12 and 14.

Increasing airflow over the module enhances the heat transfer via convection. Figure 12 shows the maximum power that can be dissipated by the module without exceeding the maximum case temperature versus local ambient temperature ( $T_A$ ) for natural convection through  $3.05 \text{ ms}^{-1}$  (600 ft./min.)

Note that the natural convection condition was measured at  $0.05 \text{ ms}^{-1}$  to  $0.1 \text{ ms}^{-1}$  (10 ft./min. to 20 ft./min.); however, systems in which these power modules may be used typically generate natural convection airflow rates of  $0.3 \text{ ms}^{-1}$  (60 ft./min.) due to other heat dissipating components in the system. Use of Figure 12 is shown in the following example.

#### Example

What is the minimum airflow necessary for a LW030A operating at 56 V input, an output current of 5.0 A, and a maximum ambient temperature of  $80 \text{ }^\circ\text{C}$ ?

Solution:

Given:  $V_I = 56 \text{ V}$ ,  $I_O = 5.0 \text{ A}$ ,  $T_A = 80 \text{ }^\circ\text{C}$   
 Determine  $P_D$  (Figure 13):  $P_D = 6.0 \text{ W}$   
 Determine Airflow (Figure 12):  $v = 1.02 \text{ ms}^{-1}$   
 (200 ft./min.)

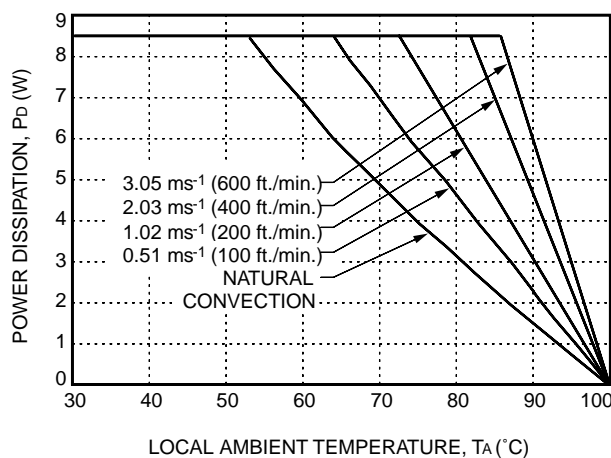

8-1155(C)

Figure 12. Convection Derating Power Derating with No Heat Sink; Either Orientation

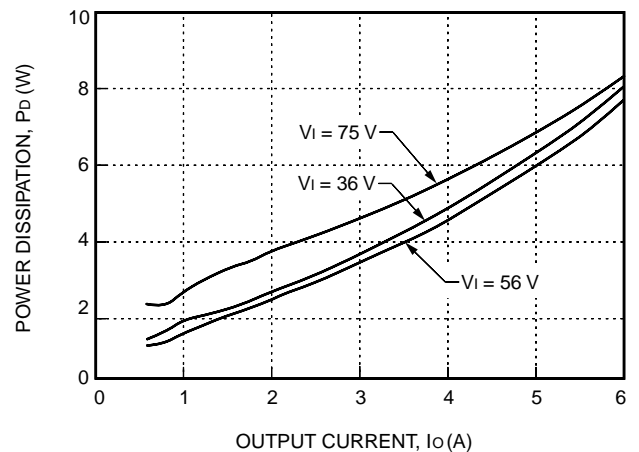

8-1267(C)

Figure 13. LW030A Power Dissipation vs. Output Current

### Heat Transfer with Heat Sinks

The LW030A module includes four through-threaded M3x0.5 mounting holes, which allow heat sinks or cold plates to be attached from either side of the module. The mounting torque must not exceed 0.56 N-m (5 in./lb.).

Thermal derating with heat sinks is expressed through use of the overall thermal resistance of the module. Total module thermal resistance ( $\theta_{CA}$ ) is defined as the maximum case temperature rise ( $\dot{\gamma}T_{C, \max}$ ) divided by the module power dissipation ( $P_D$ ):

$$\theta_{CA} = \dot{\gamma}T_{C, \max}/P_D = (T_C - T_A)/P_D$$

The location of the case temperature ( $T_C$ ) is defined in Figure 11. The case-to-ambient thermal resistance vs. airflow for various heat sink configurations is given in Figure 14. This set of curves was obtained by experimental testing of heat sinks, which are offered in the product catalog.

**Thermal Considerations** (continued)

**Heat Transfer with Heat Sinks** (continued)

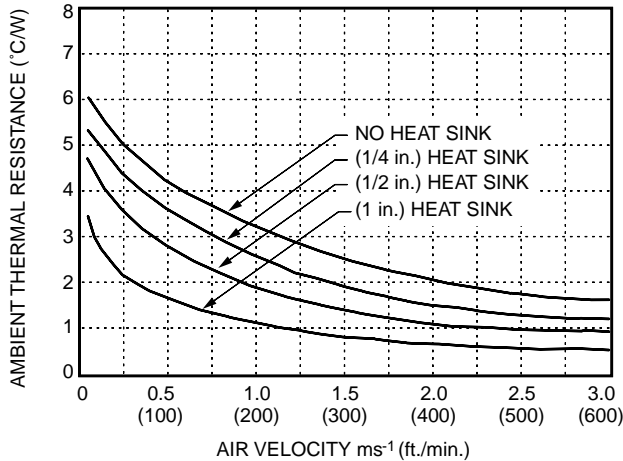

8-1157(C).b

**Figure 14. Case-to-Ambient Thermal Resistance vs. Air Velocity Curves; Either Orientation**

These measured resistances are for heat transfer from the sides and bottom of the module as well as the top side with the attached heat sink; therefore, the case-to-ambient thermal resistances shown is generally lower than the resistance of the heat sink by itself. The module used to collect the data in Figure 14 had a thermally conductive dry pad between the case and the heat sink to minimize contact resistance. Use of Figure 14 is shown in the following example.

**Example**

Although the maximum case temperature for the LW030A is 100 °C, one may want to limit the maximum case temperature to a lower value for extremely high reliability. If a 90 °C case temperature is desired, what is the allowable minimum airflow necessary for an LW030A operating at 56 V input and an output current of 6 A with a maximum ambient of 75 °C and a 1/2 in. heat sink?

Solution:

Given:  $V_i = 56 \text{ V}$ ,  $I_o = 6 \text{ A}$ ,  $T_A = 75 \text{ °C}$ , Sink = 1/2 in.  
 Determine  $P_D$  (Figure 13):  $P_D = 7.7 \text{ W}$   
 $\theta_{ca} = (T_C - T_A)/P_D$   
 $= (90 - 75)/7.7$   
 $= 1.95 \text{ °C/W}$

Use Figure 14 to determine air velocity:

1/2 in. heat sink:  $v = 0.97 \text{ ms}^{-1}$  (190 ft./min.)

**Custom Heat Sinks**

A more detailed model can be used to determine the required thermal resistance of a heat sink to provide necessary cooling. The total module resistance can be separated into a resistance from case-to-sink ( $\theta_{cs}$ ) and sink-to-sink ambient ( $\theta_{sa}$ ). This model is shown below:

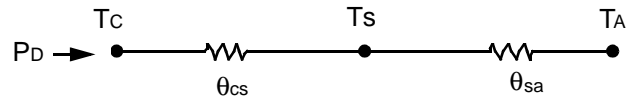

For a managed interface using thermal grease or foils, a value of  $\theta_{cs} = 0.1 \text{ °C/W} - 0.3 \text{ °C/W}$  is typical. Solution for the heat sink resistance is:

$$\theta_{sa} = [(T_C - T_A)/P_D] - \theta_{cs}$$

Note that this equation assumes that all dissipated power must be shed by the heat sink. Depending on the user-defined application environment, a more accurate model including heat transfer from the sides and bottom of the module can be used. This equation provides a conservative estimate in such instances.

## Outline Diagram

Dimensions are in millimeters and (inches).

Copper paths must not be routed beneath the power module case edge.

Tolerances:  $x.x \pm 0.5$  mm (0.02 in.),  $x.xx \pm 0.25$  mm (0.010 in.).

**Note:** For standard modules,  $V_I(+)$  is internally connected to the case.

### Top View

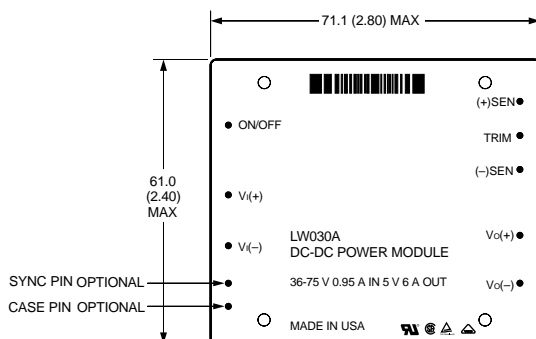

### Side View

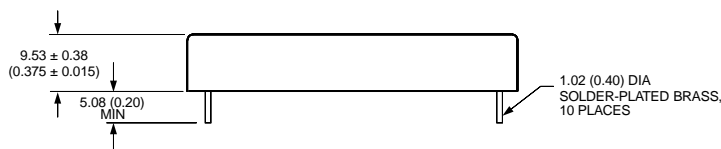

### Bottom View

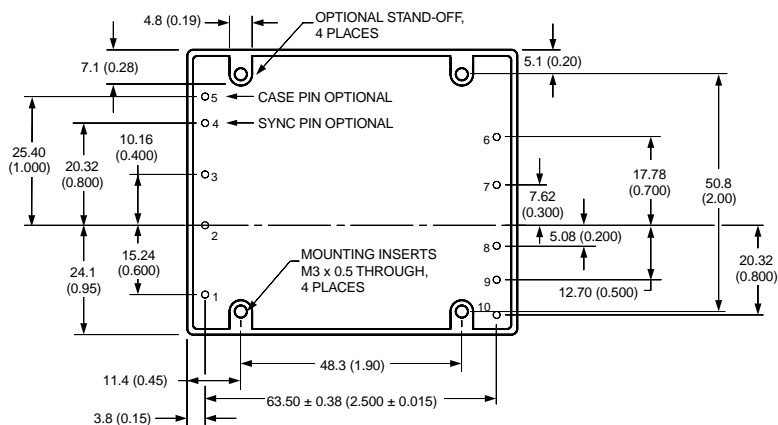

Pin	Function
1	Remote On/Off
2	$V_I(+)$
3	$V_I(-)$
4	Sync Pin (optional)
5	Case Pin (optional)
6	-Output
7	+Output
8	-Sense
9	Trim
10	+Sense

8-1177(C).a

## Recommended Hole Pattern

Component-side footprint.

Dimensions are in millimeters and (inches).

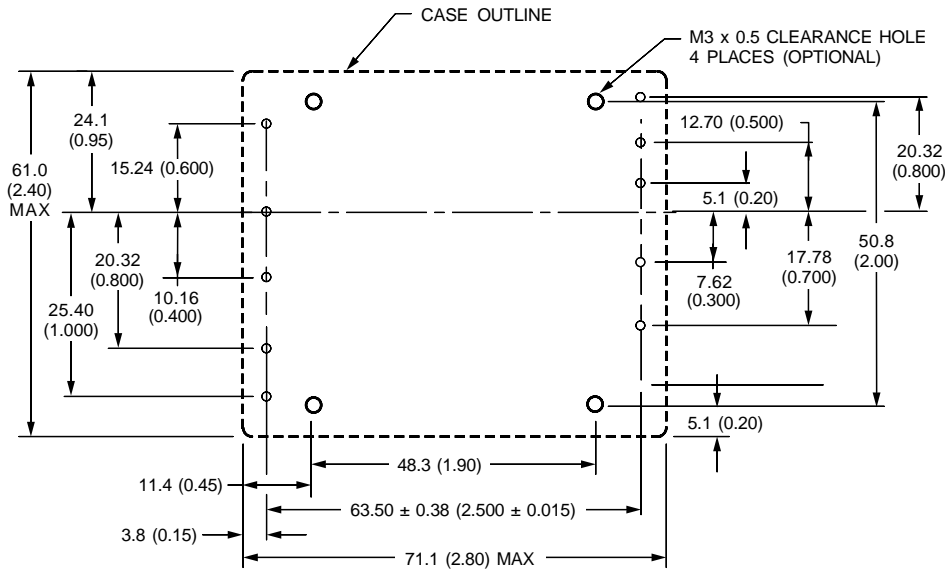

8-1177(C),b

## Ordering Information

Input Voltage	Output Voltage	Output Power	Device Code	Comcode
48 V	5 V	30 W	LW030A	107314296

Optional features may be ordered using the device code suffixes shown below. To order more than one option, list suffixes in numerically descending order.

Option	Device Code Suffix
Case Gnd Pin	7
Sync	3
Negative Logic Remote On/Off	1

Please contact your Tyco Electronics' Account Manager or Field Application Engineer for pricing and availability.

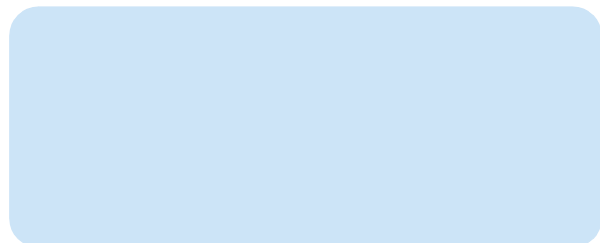

Tyco Electronics Corporation reserves the right to make changes to the product(s) or information contained herein without notice. No liability is assumed as a result of their use or application. No rights under any patent accompany the sale of any such product(s) or information.

© 2001 Tyco Electronics Corporation, Harrisburg, PA. All International Rights Reserved.  
Printed in U.S.A.

July 1997  
DS97-207EPS (Replaces DS95-087EPS)

